

# DF130

## MOBILE FOAM UNIT



### High Capacity Foam Station for Major Risks

- 130 Litre Capacity
- Highly Mobile
- One Man Operation
- Long Running Times
- M.C.A. Approved
- Lloyds Certified
- Suitable for All Foam Compounds



Available with All International Fittings

## GENERAL DESCRIPTION

The DF130 Mobile Foam Unit, ideal for protecting oil storage and loading terminals, paint and solvent stores, boiler engine rooms and other high risk areas, is ergonomically designed for rapid one man deployment. The unit requires connection to a suitable pressurised water supply. Filled with 3% foam concentrate, the DF130 will give running times in excess of 20 minutes, with a foam output of over 34,000 Litres of finished low expansion foam.

## CONSTRUCTION

Foam Tank: 130L Capacity Chemically Resistant International Orange GRP tank suitable for all foam types including Synthetic, Protein, Fluoroprotein, AFFF, FFFP and Alcohol Resistant

Chassis: Corrosion Resistant Plastic coated steel frame

Wheels: 400mm Diameter, solid rubber tyres

## FITTINGS

Standard: HV225 Low Expansion Foam Branchpipe  
Z225 Variable Inline Foam Inductor with On/Off ballvalve  
2 x 15m x 45mm Nova Fire Hoses to BS 6391 Type 3  
2½" Instantaneous Light Alloy fitting to BS 336

## MODELS

Any of the range of Delta Foam Branchpipes with matching Inductor may be specified including all Delta Low and Medium Expansion Branchpipes. Flows 225, 450 and 900 Litres/Min.

Alternative fittings:  
Storz, American NST or any other International fittings and couplings may be specified  
Light Alloy or Gunmetal

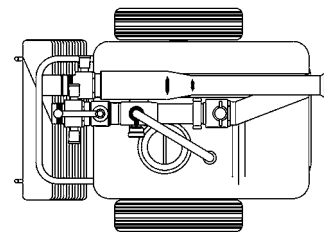

910mm

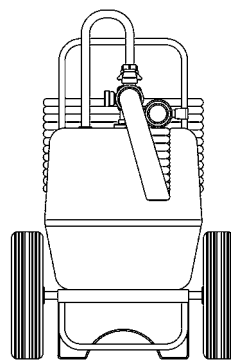

710mm

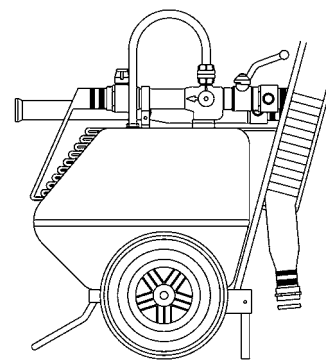

1020mm

Size:- 1020mm (H) x 910mm (L) x 710mm (W) (Overall)  
Weight:- 70kg (Empty)